



Blade

because it's KEF

For audiophiles all over the world, KEF has for 50 years been synonymous with innovative acoustic engineering in pursuit of outstanding sound quality. We have the awards and reputation to prove it: for more than two generations, no other manufacturer has done more to advance the state of the art.

Ever since KEF was founded by ex-BBC electronics engineer and loudspeaker guru Raymond Cooke in 1961, we've been leading the progress of audio technology - and as the latest expression of this passionate engagement with fresh ideas, advanced materials and new technologies to enhance the pleasures of recorded music, Blade is pure KEF.

"Of all the arts, music is the most indefinable and the most expressive, the most insubstantial and the most immediate, the most transitory and the most imperishable. Transformed to a dance of electrons along a wire, its ghost lives on. When KEF returns music to its rightful habituation, your ears and mind, they aim to do so in the most natural way they can - without drama, without exaggeration, without artifice."

Raymond Cooke



from concept

The inspiration was simple: to give some of the world's most talented audio engineers complete freedom to create a speaker to showcase KEF's technology leadership and powers of innovation. No preconceptions. No need to use existing components. And no design or cost restrictions whatsoever.

After three years of original research and exhaustive testing, what our team came up with looked and sounded like no other speaker: Concept Blade, whose startling acoustic precision was so enthusiastically acclaimed when it was first revealed at the Munich High End Show in 2009.

But unlike glamorously radical concept cars that never see production, we decided it was simply too good not to take a step further. Encouraged by all the reviews, and to mark KEF's 50th anniversary, the design team was given the go-ahead to develop this stunning concept for production, and two more years were spent painstakingly refining the concept to produce an edition that serious audiophiles could actually own.

to reality

We devised ingenious applications of different new materials to replicate the shattering performance of the original, using innovative technologies to deliver the acoustic capabilities required of such a super-premium product. We perfected a method of manufacturing the complex parabolic enclosures. The drivers gained sophisticated enhancements to recapture the magic of listening to the one-off prototype. What was previously thought impossible was set to become a reality.

The resulting KEF Blade is a unique synthesis of cutting edge audio technology and groundbreaking design. While the technologies involved are very advanced, the original focus on simplicity remains. Every single component operates so comfortably within its performance envelope that they work together as a single, flawlessly coherent unit - in effect, a giant full-range Uni-Q® driver array.

It's a spectacularly lush, warm and expansive sound. Effortlessly accurate, and as natural, intricate and emotionally authentic as a live performance. If you're passionate about music, we think you'll agree that the years of development that made the concept a reality were very well spent indeed.





a passion for innovation

KEF's ethos has always been based on the continuing quest to find new and better ways of reproducing recorded sound – it's in our DNA. Although this spirit has, over the years, generated more innovations than there's space to cover here, the most influential have transformed the entire discipline of loudspeaker design.

KEF was the first to apply computerised techniques to optimising speaker performance, for example. We pioneered driver decoupling. Pair matching. Coupled cavity bass loading. Conjugate load matching. Acoustic compliance enhancement. Aerospace-derived modelling techniques such as finite element analysis.

Of all these landmark innovations, the most influential is the Uni-Q 'point source' driver configuration that's now our signature technology. And no wonder: Uni-Q's outstanding clarity and broad dispersion characteristics deliver superbly defined sonic imagery over a listening area no conventional speaker can rival. After decades of continuous development, the latest Uni-Q driver arrays are to be found on all high end KEF speakers, up to and including the phenomenal Ross Lovegrove-designed Muon - arguably the most extraordinary audio speaker ever conceived.











redefining the possible

The Blade was designed from the start with a single objective: to extend the boundaries of what high end audio can achieve. Its exceptional acoustic integrity derives from the combination of carefully chosen components, new high performance drivers designed to behave with no break-up or resonance over their required frequency range and an inert cabinet engineered never to interfere with the uncompromised purity of their output.

You don't have to be an audiophile to hear that the upper registers of familiar tracks sound noticeably sweeter and more detailed as a result, or that the exceptionally clean, tight bass sounds far more full-bodied. But if you are, the Blade is an investment in a lifetime of listening pleasure.





Conventional speaker array with radiation from multiple points causes interference and blurring



single apparent source

Like listening to one voice rather than many, sound from a single source is inherently clearer. Not only are the acoustic centres of the HF and MF drivers in the Blade's Uni-Q array coincident, but the four LF drivers are mounted symmetrically equidistant from it so that their acoustic centres occupy exactly the same point in space.

This single apparent source configuration is what makes the Blade so gratifyingly coherent across the frequency range, with noticeably more precise imaging than is possible from any conventional speaker.

What you hear sounds as if it's being performed live right in front of you.

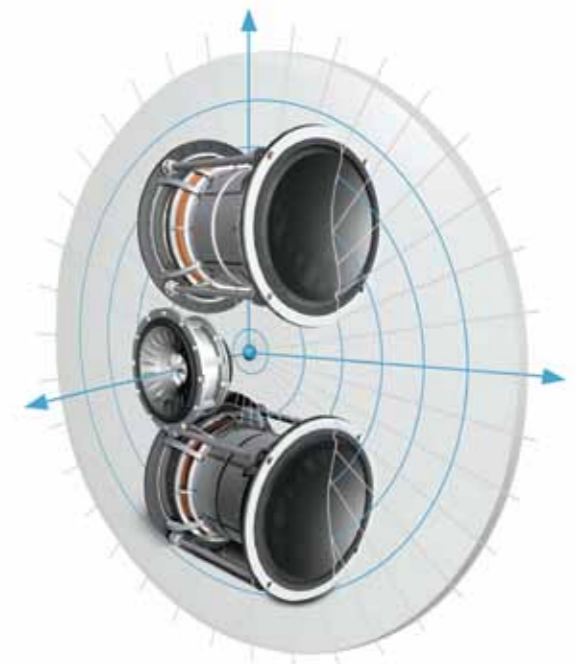

Single Apparent Source, clean sound radiation from one point in space

advanced acoustic technologies

Uni-Q driver array

MF hybrid cone

So light and rigid that it never reaches its natural break-up point, the Blade's hybrid MF cone has an outer skin of lithium/magnesium/aluminium alloy braced at the back by a precision-engineered skeleton of liquid crystal polymer, which not only aids stiffness but also vents the confined space between the cone and voice coil. By optimising sensitivity and transient response, this unique combination reproduces upper midrange frequencies with an accuracy that allows you to enjoy the full subtlety of emotionally nuanced performances, especially with vocals and keyboards.

MF cone shape with smooth surround

Both the shape of the tweeter dome and the contours of the midrange horn are optimised to flatten HF response compared to a conventional baffle, and the surround is carefully designed to ensure an immaculately smooth transition to the cabinet.

The entire Uni-Q driver array is fully decoupled to prevent unwanted vibrations from muddying the sound you hear; allowing the harmonics of live vocal and instrumental performances to be flawlessly reproduced.

Large voice coil with nodal drive

To boost power handling and minimise thermal compression effects, the midrange cone is driven by a much larger voice coil than is usual, playing more loudly and more cleanly than any previous Uni-Q driver array and investing the music with compellingly natural dynamics. And because this large voice

coil further stiffens the cone by bearing on the exact point of its first resonant mode rather than the neck, it contributes to the cone's reassuringly high break-up frequency.

The Uni-Q driver array

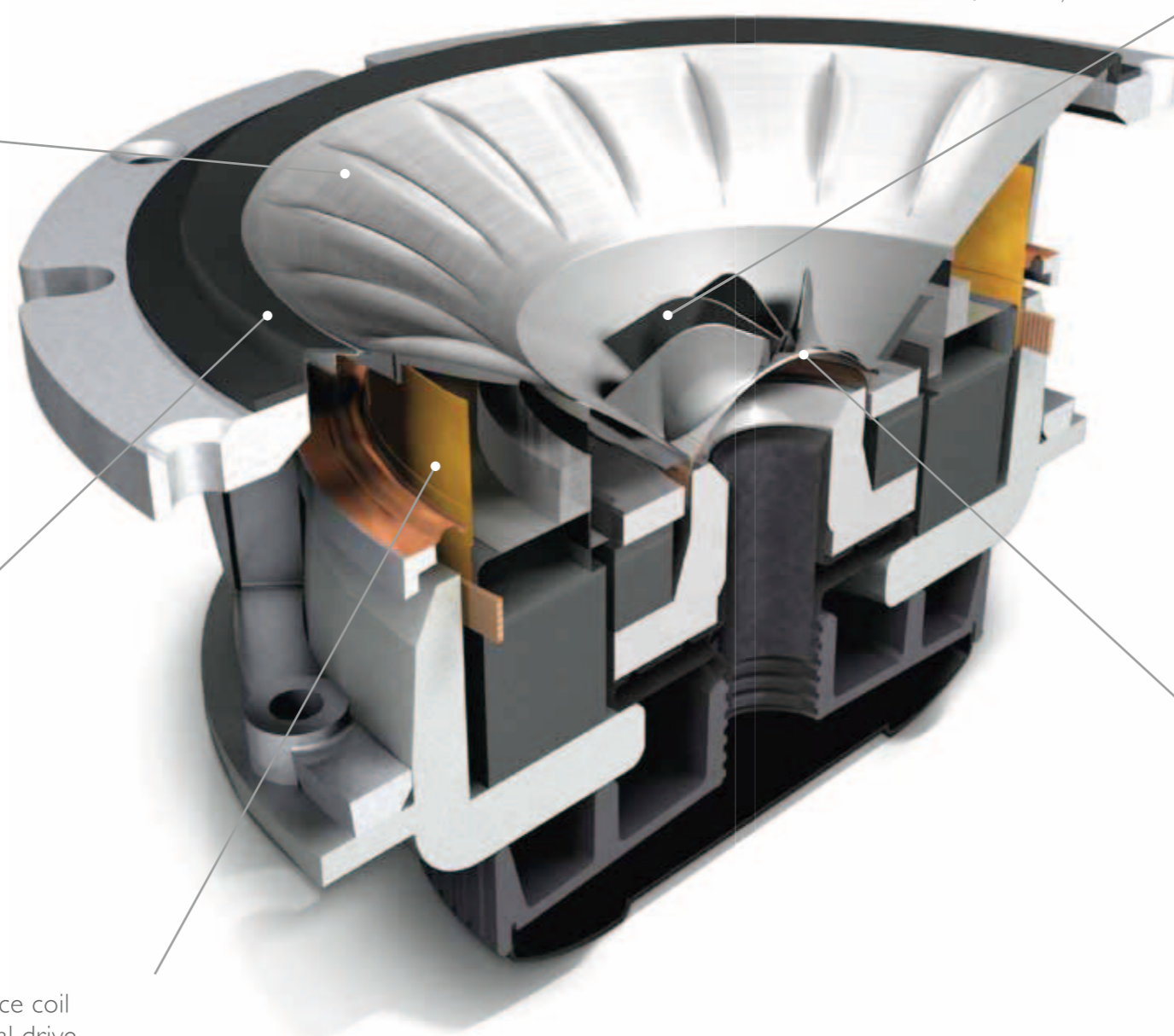

Tangerine waveguide

Developed from our high performance professional drivers, this patented waveguide widens the dispersion of high frequencies; instead of beaming forwards, it recreates the wide, even dispersion of a natural soundfield, minimising traditional sweet spot effects so that the astonishingly pure HF imaging is shared by everyone in the room.



The tweeter is vented to eliminate distortion and pressure behind the tweeter dome

Tweeter

With its stiffened, computer-optimised dome and 'tangerine' waveguide, the Blade tweeter (vented to eliminate distortion from compressing the air behind) operates pistonically over its entire working range for the greatest

clarity and transparency, with nothing added to or subtracted from the sound originally recorded. Whatever the volume or the musical genre, HF response is consistently sweet, lucid and lyrical.

The tweeter has a two-part dome construction that forms a triangular strut to increase rigidity

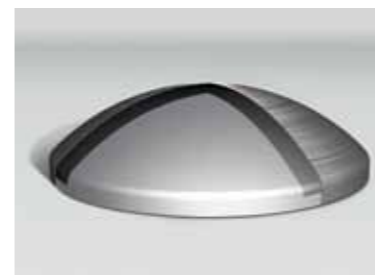

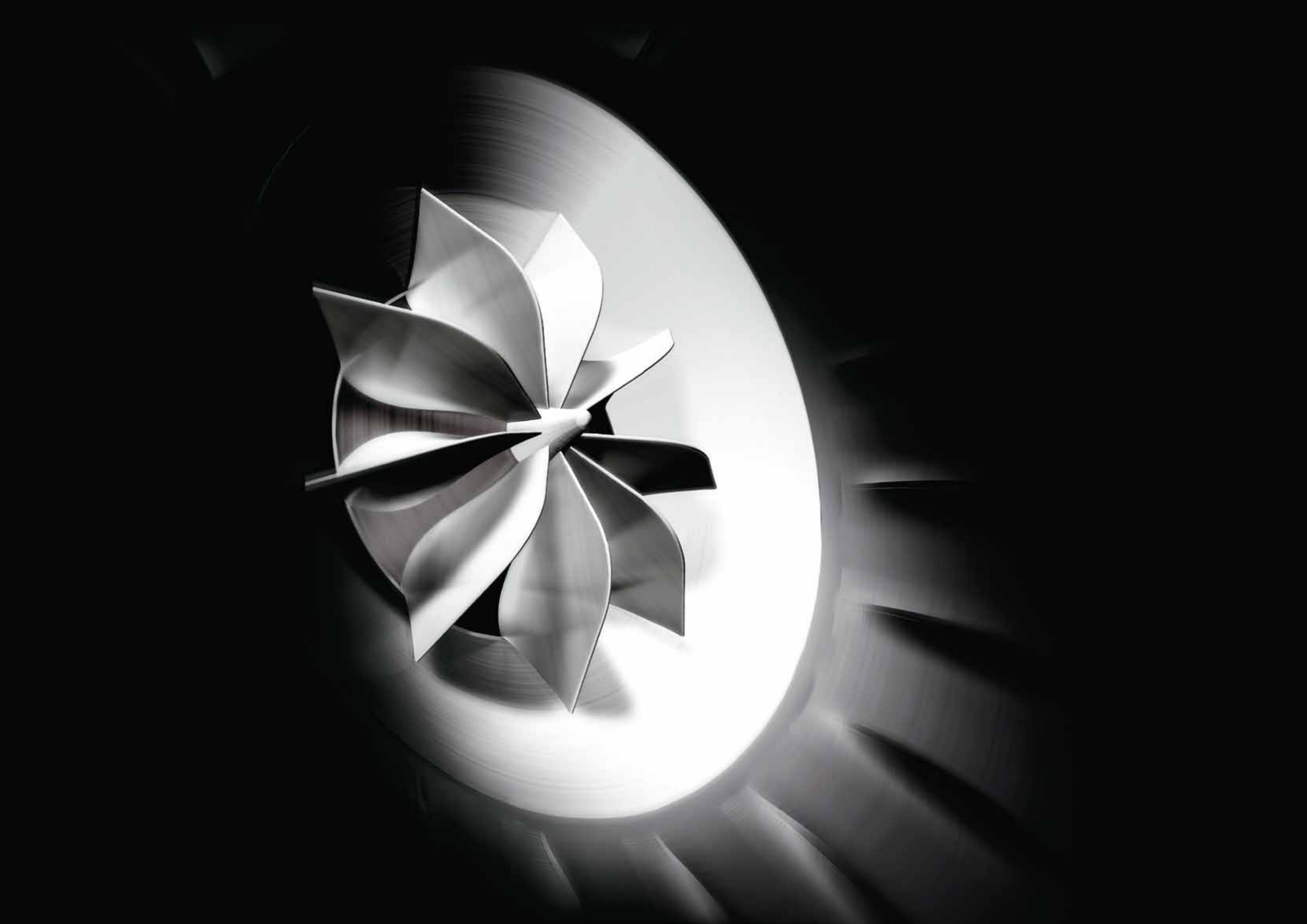

Bass

LF driver

After two years of intensive development, the four powerful new 9" (225mm) LF drivers of the Blade are perfectly integrated with the Uni-Q and generate an even deeper, cleaner and more authoritative bass than the larger units in the original concept.

By maximising extension in line with output, this formidable array is capable of delivering seismic punch when required while also retaining the delicacy and musicality you would experience if you were in the room with the original artists.

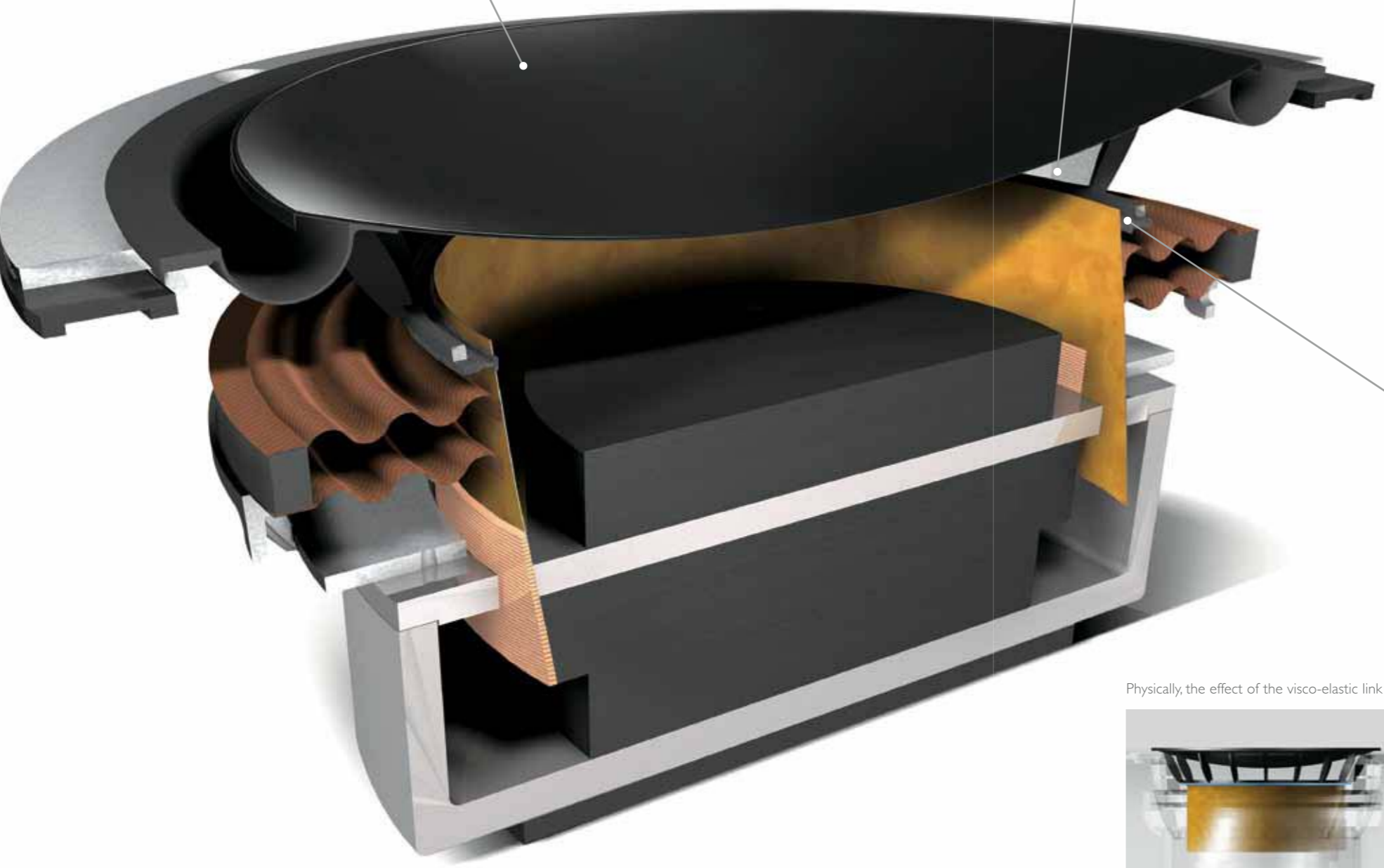

Vented coupler

Although large voice coils maximise power handling, turbulent air trapped inside can cause distortion. This has been engineered out of the Blade by venting the spacer above the voice coil to allow the air to escape freely, however hard they are driven.

LF performance therefore remains lucid, clean and involving when playing loud.



Conventional driver traps air inside

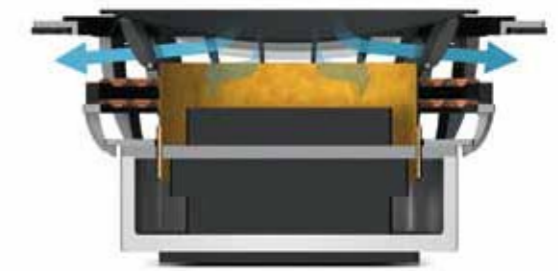

Blade driver with a vented coupler

Decoupled diaphragm

Instead of using high order crossovers to prevent the LF cone from reaching its break-up frequency, the voice coil is decoupled from the diaphragm by a visco-elastic link.

This allows the Blade to exploit the acoustic advantages of low order crossovers: purer sound reproduction and silkier bass response, irrespective of volume.

Physically, the effect of the visco-elastic link is very similar to the way that a car suspension works in absorbing undulations in the road surface

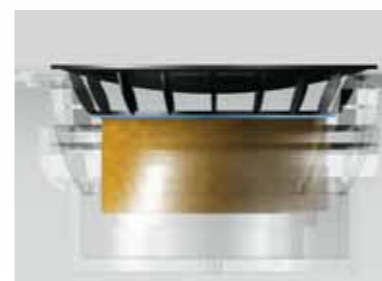

Force cancelling

To avoid dissipating the energy of such potent bass drivers in exciting the cabinet (and thereby generating resonance, especially at high volume), the large kinetic forces involved are cancelled out by mounting the LF drivers rigidly together, back-to-back.

By minimising cabinet colouration, this highly effective configuration partly accounts for the Blade's natural-sounding and engagingly musical performance.



Conventional speaker generating cabinet resonance



With Blade, the forces cancel each other out to minimise resonance

Discrete bass chambers

The twinned pairs of bass drivers are mounted in discrete chambers separated by an internal partition. By increasing the frequency of any internal standing waves to way beyond the crossover point, this reduces the need for damping material (which can otherwise impair bass quality). Nothing has been overlooked in the quest for the ultimate clarity, right across the frequency range.



attention to detail

With a speaker as ambitious as the Blade, short cuts are out of the question. Everything has to be as right as it can possibly be.

Terminals & terminal links

Two pairs of the finest audiophile quality WBT connectors allow bi-wiring or bi-amping to optimise the retrieval of low level detail in the music.

Low order crossovers

The simple low order crossovers specified for the Blade employ the best components available, carefully selected by a rigorous auditioning process so that every part of the signal path is fine-tuned for maximum clarity.

Hard wiring

The patented screw-in linking plugs are to full audiophile specification (as well as simplifying set-up by eliminating fiddly wiring links). All the crossover components are individually wired by hand rather than mounted on a conventional printed circuit board. As well as being more environment-friendly, this optimises both reliability and sound quality by assuring the cleanest possible signal transmission.

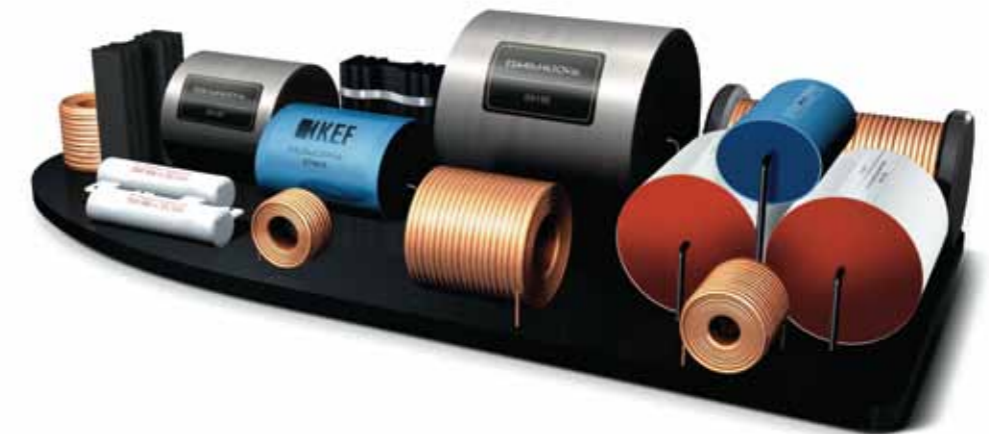



Eric Chan, ECCO Design Inc.

design and designers

The challenge was to design an acoustically efficient enclosure for a sizeable speaker whose driver configuration demanded large capacity at the upper portion, without looking at all bulky.

Initially, our team worked alongside Eric Chan of New York-based ECCO Design to create a distinctive visual identity for a speaker of such towering performance capabilities. As functional as they are beautiful, the resulting cabinets are like works of art in their own right - indeed, their form was inspired by Brancusi's seminal Modernist masterpiece 'Bird in Space'.

Tapering gracefully from top to bottom and from front to rear, the slim proportions made possible by the orientation of the bass drivers give the Blade a sculptural presence in its own right, with a single continuous keyline describing a taut, seamless curve along the back edge and over the top.

Glass-reinforced composite



This award-winning form was dictated by acoustic considerations rather than mere styling: the gentle radius of the front face presents the sound with no discontinuity to mar its clarity. The cabinets are constructed from a glass-reinforced composite, an inert and exceptionally rigid material that lends itself to forming the complex parabolic curves that help to eliminate any internal standing waves that might otherwise blur the output.

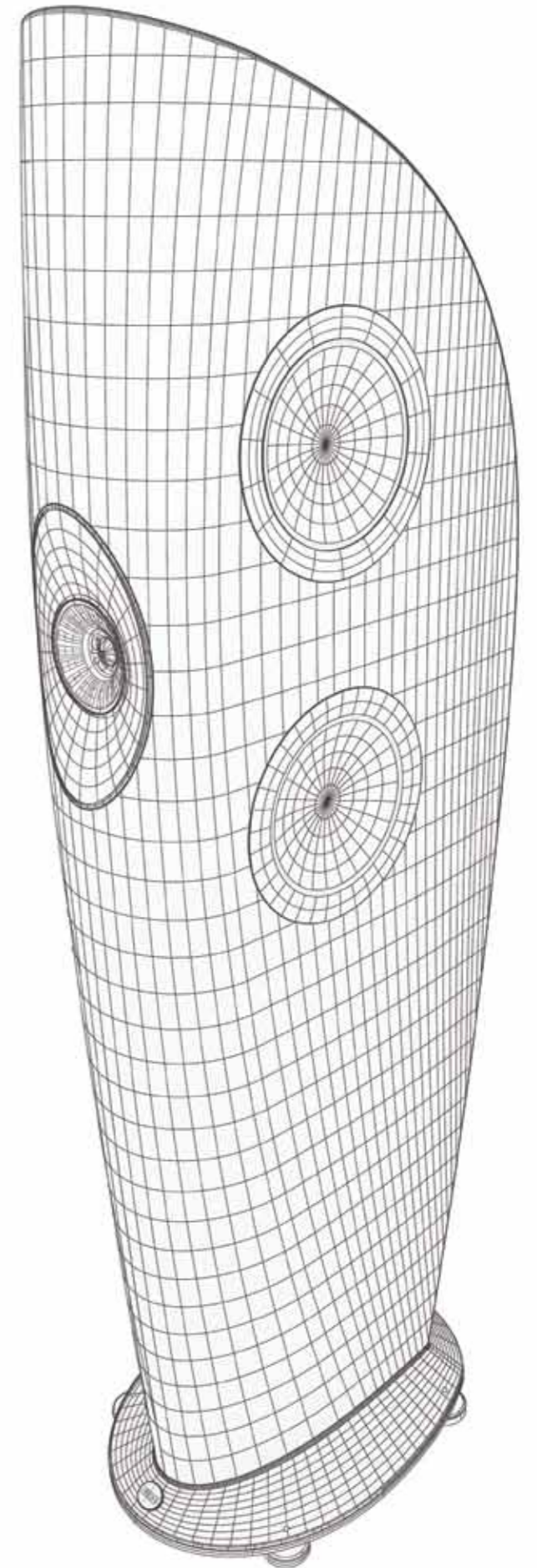

Standard colours

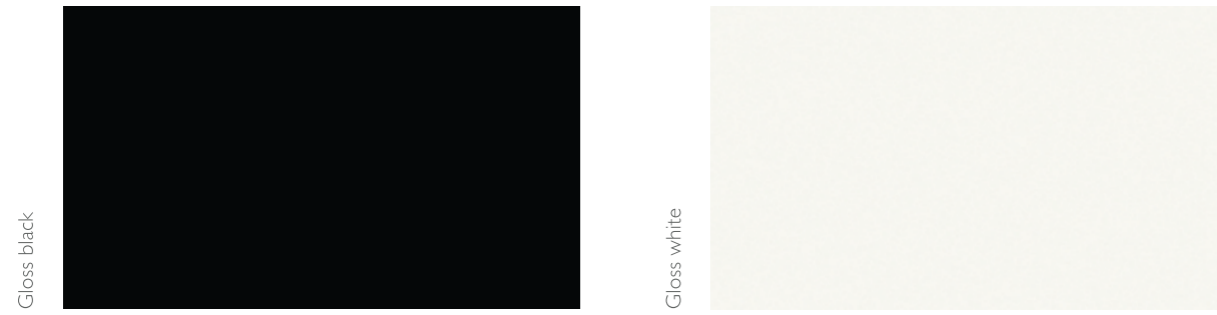

Custom colours



finishes

The standard finish options for the Blade reflect the theme of simplicity executed with excellence: pure gloss white or pure gloss black. For those with more exuberant tastes, 12 sumptuous high gloss custom lacquer finishes are available to special order - given time, we'll even quote to match any colour you specify. Like everything else about the Blade, it's about perfectionism.

Just as KEF's philosophy has always been to use innovation to perfect more accurate and realistic ways of replicating recorded sound, the Blade is about perfecting a groundbreaking concept for production. Whatever your taste in music, the result is what all great design aspires to: being the best it can possibly be.



specifications

Blade

Design	Three-way bass reflex, Single Apparent Source driver configuration
Drive units	Uni-Q driver array: MF: 125mm (5in.) Li-Mg-Al /LCP hybrid cone HF: 25mm (1in.) Al dome Bass units: LF: 4 x 225mm (9in.) with force cancelling
Frequency response	40Hz - 35kHz \pm 3dB (-6dB at 28Hz)
Crossover frequencies	350Hz, 2.3kHz
Amplifier requirements	50-400W
Sensitivity (2.83V/1m)	91dB
Maximum output (SPL)	117dB
Nominal impedance	4 Ω (3.2 Ω min.)
Weight	57.2 kg (126 lbs)
Dimensions (H x W x D)	1590 x 363 x 540 mm 62.5 x 14.3 x 21.2 in.
Standard finishes	Gloss black or gloss white
Custom colours	Garnet, Sapphire, Grigio, Racing red, Racing blue, Pale gold, Orange sorbet, Graphite, Stardust, Lemon sorbet, Lime sorbet or Snow white

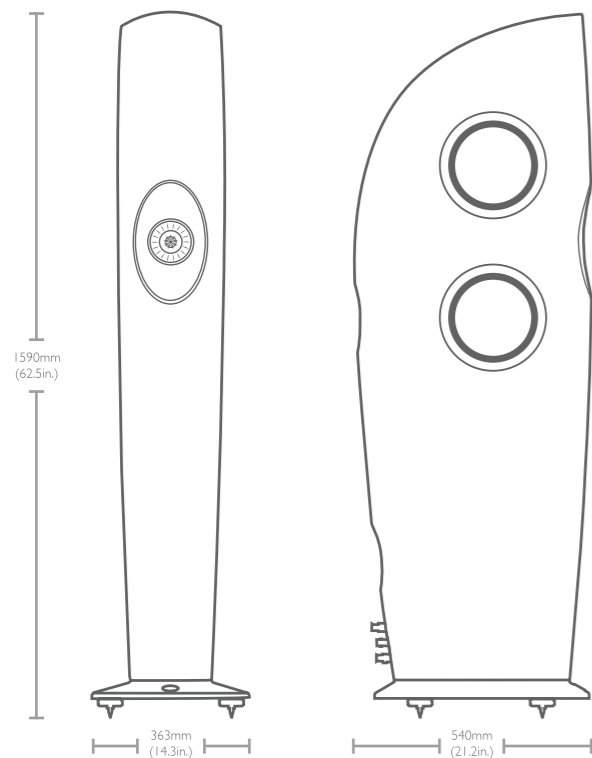

* KEF reserves the right, in line with continuing research and development, to amend or change specifications. E&OE.

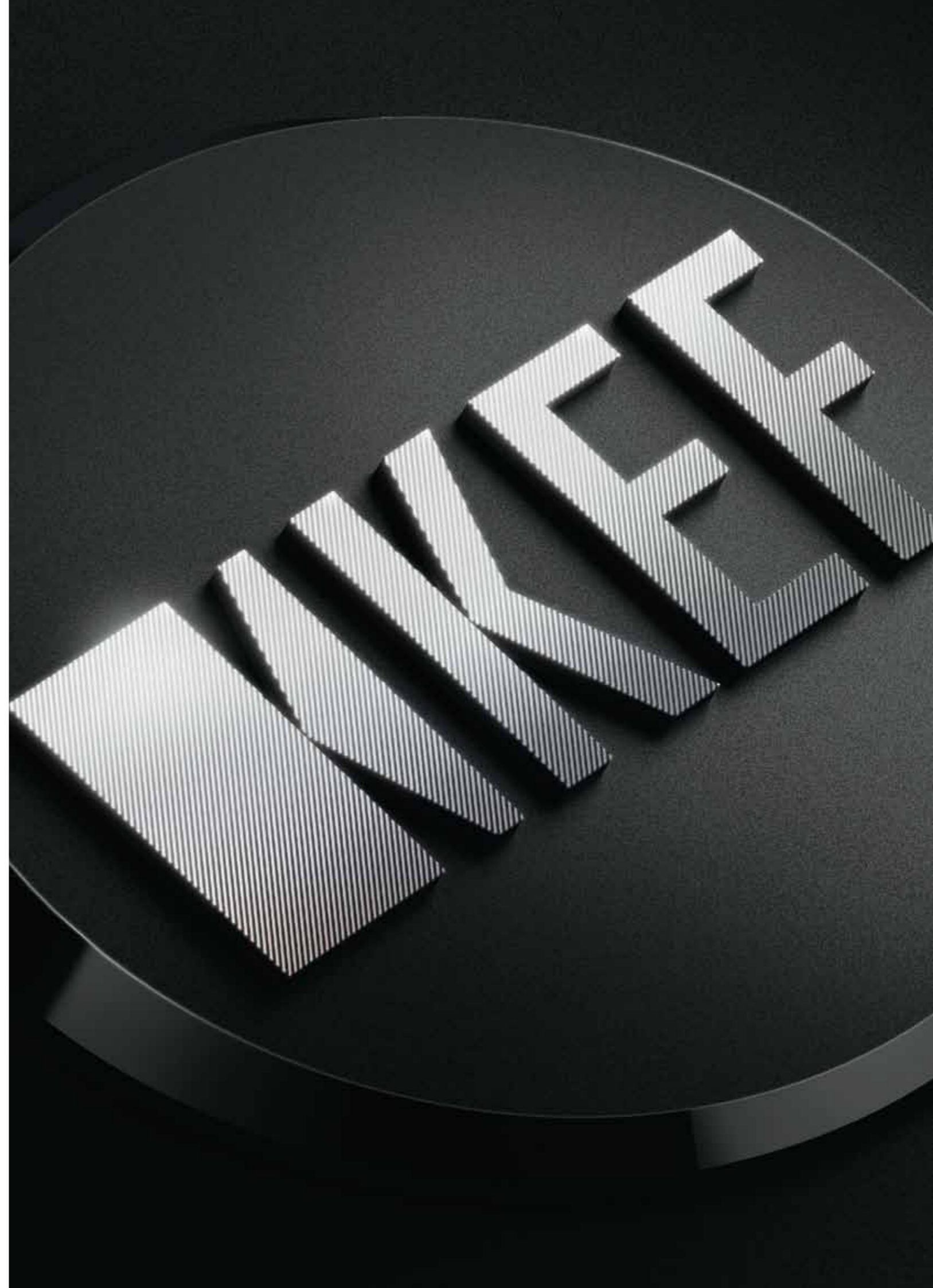





www.kef.com

United Kingdom

GP Acoustics (UK) Limited
Eccleston Road, Tovil, Maidstone
Kent, ME15 6QP U.K.
Tel: +44 (0) 1622 672261
Fax: +44 (0) 1622 750653
Email: info@kef.com

China

GP Acoustics (China) Limited
Unit 4910, Diwang Commercial Centre
Shenzhen, China 518008
Tel: +86 (755) 8246 0746
Fax: +86 (755) 8246 0125
Email: info.prc@gpe-hkg.com

Europe (EMEA)

GP Acoustics GmbH
Am Brambusch 22, 44536, Lünen
Deutschland
Tel: +49 (0) 231 9860-320
Fax: +49 (0) 231 9860-330
Email: sales@gpaeu.com

France

GP Acoustics (France) SAS
39 Rue des Granges Galand - BP60414
37554 Saint-Avertin CEDEX, France
Tel: +33 (0) 2 47 80 49 01
Fax: +33 (0) 2 47 27 89 64
Email: info.france@kef.com

Hong Kong

GP Acoustics (HK) Limited
6F, Gold Peak Building
30 Kwai Wing Road, Kwai Chung
N.T., Hong Kong
Tel: +852 2410 8188
Fax: +852 2401 0754
Email: info@gpacoustics.com.hk

Japan

KEF Japan, 1-11-17, Honcho, Koganei-city
Tokyo, Japan. 184-0004
Tel: +81 (0) 42-388-2030
E-mail: info@kef.jp

Taiwan

GP Acoustics (Taiwan) Limited
Room 4B, 5F, 415, Xingyi Road Sec 4
Taipei 110, Taiwan
Tel: +886 (2) 2723 0868
Fax: +886 (2) 2723 0818
Email: info@gpacoustics.com.tw

USA

GP Acoustics (US) Inc.
10 Timber Lane, Marlboro
New Jersey 07746 U.S.A.
Tel: +1 (732) 683 2356
Fax: +1 (732) 683 2358
Email: sales@kefamerica.com



Designed and Manufactured
in the United Kingdom



KEF and Uni-Q are registered trademarks. Uni-Q and other KEF technologies are protected by worldwide patents. All text and image copyrights reserved.

English PM-BladeLB-EN I I