

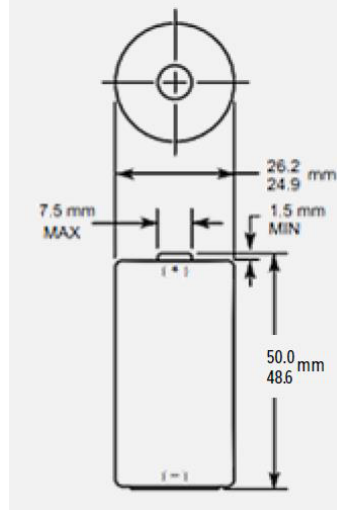

Size: C (LR14) MN1400



Dimensions shown are IEC standards

### Key Features

- Reliable Performance
- Excellent resistance to corrosion
- Designed to meet all major quality, safety and environmental standards:
  - Safety: IEC 60086-5
  - ANSI C 18.1M, Part-2
  - EU Battery Directive
  - Quality: ISO 14001 and 9001, Duracell World Class Continuous Improvement Program

### Electrical Characteristics

- Nominal capacity (83 mA Cont., .8V cut-off) 6,235 mAh
- Typical Voltage (at + 20 °C) 1.5 V
- AC Impedance @ 1kHz 112 mΩ

### Physical Characteristics

- Typical weight 69.0 g (2.4 oz)
- Typical volume 26.9 cm<sup>3</sup> (1.6 in<sup>3</sup>)
- Terminals Flat

### Operating & Storage Conditions

- Operating temperature range -20°C to 60°C (-4°F to 140°F)
- Storage temperatures Recommended 5°C to 30°C (41°F to 86°F)

Delivered capacity is dependent on the applied load, operating temperature and cut-off voltage. Please refer to the charts and discharge data shown for examples of the energy/service life that the battery will provide for various load conditions.

### Typical Performance

Constant Current

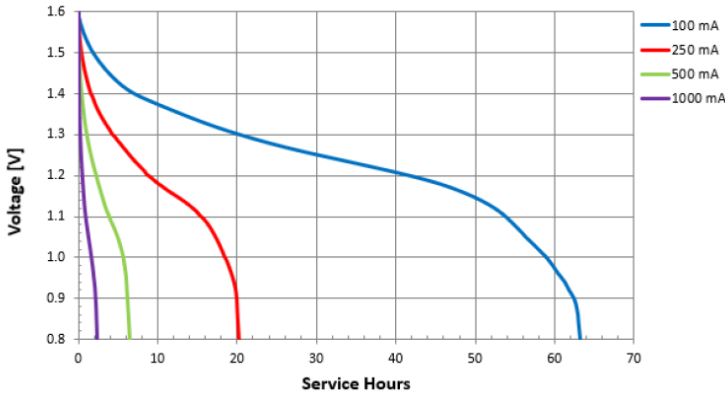

Constant Resistance

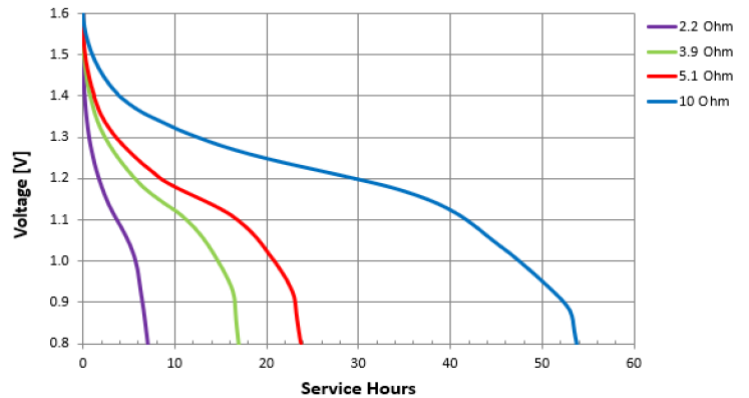

Constant Power

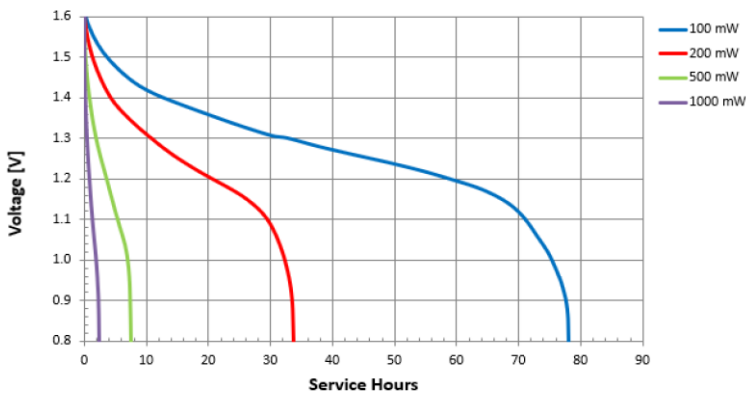

Constant Temperature - 100 mA

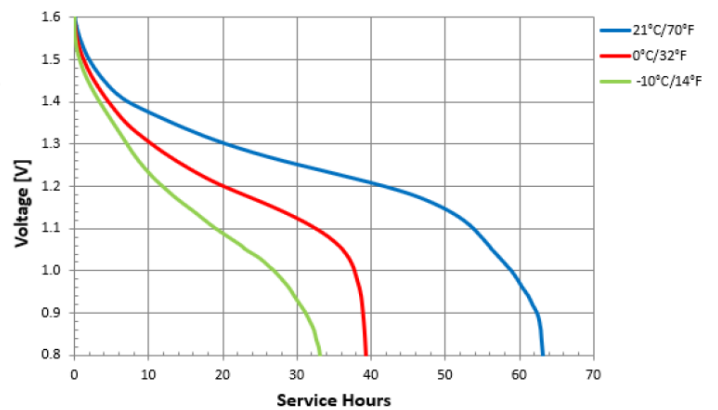

Delivered capacity is dependent on the applied load, operating temperature and cut-off voltage. Please refer to the charts and discharge data shown for examples of the energy/service life that the battery will provide for various load conditions.